

Data Sheet CycloFlex FPGA Development System

**CYCLOFLEX**  
**FPGA DEVELOPMENT SYSTEM**  
**Data Sheet**

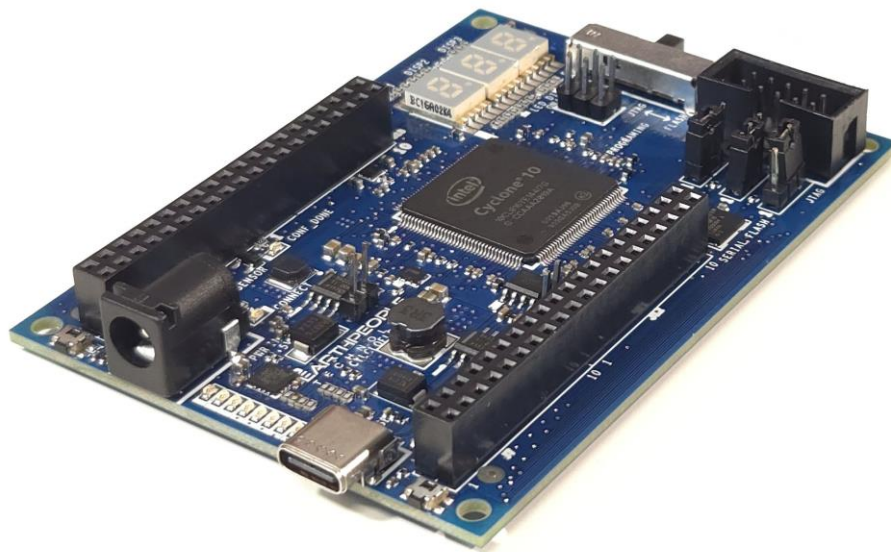

The CycloFlex is an FPGA development board that is designed for the intermediate user with some experience designing FPGA projects.

The CycloFlex is packed with powerful features. The core of the CycloFlex is the Altera Cyclone 10 FPGA. This powerful chip has 16,000 Logic Elements and 504Kbits of Memory. The board includes a 128Mbit Serial Flash chip which allows the board to store up user code for using the FPGA as RISC V soft processor. There are three Green Seven Segment LED Displays, RGB LED and Eight User LEDs. It allows the creation of more diverse projects than beginner



Data Sheet CycloFlex FPGA Development System

projects.

### CycloFlex Hardware Features

- Cyclone 10 10M04SA FPGA From ALTERA
- 16,000 Logic Elements; 504 Kbit On Chip SRAM
- 65 Available I/O's at connectors
- Three Seven Segment LEDs
- 8 Green User configurable LEDs
- RGB LED
- 2 User Configurable Pushbutton Switch
- On Board 128Mbyte Flash
- Two Power options: Standard USB (+5V @ 2Amp) Using Micro-B connector;
- 5mm Barrel Connector Accepts +5V @ 3Amp
- Switching Power Supply, Provides stable output under high load stress
- 50MHz Oscillator
- On board USB to Slave SPI Adapter for high speed communications

Data Sheet CycloFlex FPGA Development System

## 1 Block Diagram

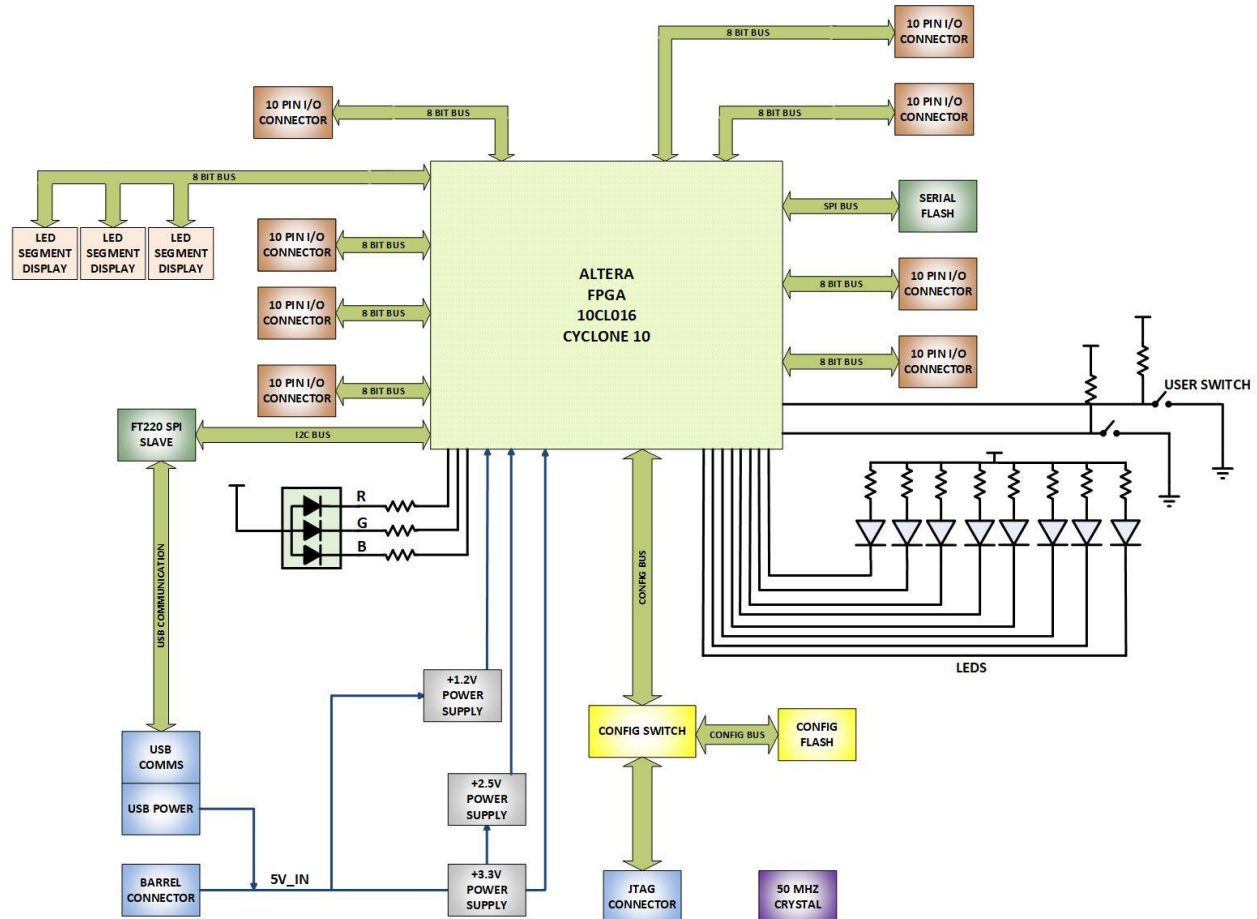

## 2 Mechanical Dimensions

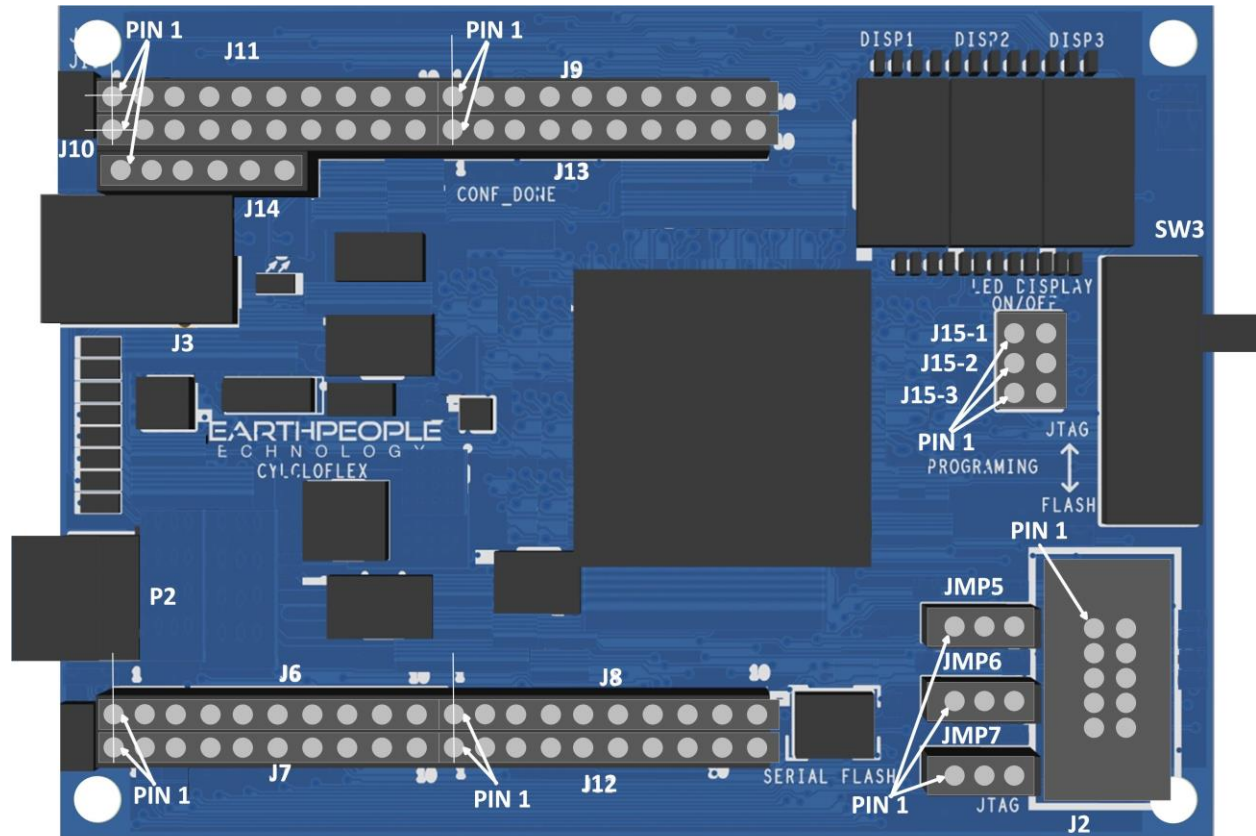

## 3 Pin Mapping

Pin Mapping between CycloFlex Connectors and FPGA User code

Connector-Pin #	Net Name	Cyclone 10 FPGA Pin Number	User Code Signal Name
J11-1	UB56	135	XIO_1[0]
J11-2	UB49	134	XIO_1[1]
J11-3	UB31	136	XIO_1[2]



Data Sheet CycloFlex FPGA Development System

J11-4	UB57	137	XIO_1[3]
J11-5	UB30	141	XIO_1[4]
J11-6	UB48	142	XIO_1[5]
J11-7	UB47	143	XIO_1[6]
J11-8	UB46	144	XIO_1[7]
J11-9	+3.3V	NC	NC
J11-10	+3.3V	NC	NC

Connector-Pin #	Net Name	Cyclone 10 Pin Number	User Code Signal Name
J9-1	UB37	80	XIO_2[0]
J9-2	UB36	83	XIO_2 [1]
J9-3	UB21	85	XIO_2 [2]
J9-4	UB50	98	XIO_2 [3]
J9-5	UB51	99	XIO_2 [4]
J9-6	UB35	100	XIO_2 [5]
J9-7	UB52	101	XIO_2 [6]
J9-8	UB53	103	XIO_2 [7]
J9-9	GND	NC	NC
J9-10	GND	NC	NC



Data Sheet CycloFlex FPGA Development System

Connector-Pin #	Net Name	Cyclone 10 Pin Number	User Code Signal Name
J10-1	UB34	105	XIO_3[7]
J10-2	UB33	111	XIO_3[6]
J10-3	UB23	112	XIO_3[5]
J10-4	UB24	113	XIO_3[4]
J10-5	UB25	114	XIO_3[3]
J10-6	UB32	119	XIO_3[2]
J10-7	UB54	132	XIO_3[1]
J10-8	UB55	133	XIO_3[0]
J10-9	GND	NC	NC
J10-10	GND	NC	NC

Connector-Pin #	Net Name	Cyclone 10 Pin Number	User Code Signal Name
J13-1	UB60	52	XIO_4[0]
J13-2	UB61	53	XIO_4[1]
J13-3	UB62	54	XIO_4[2]
J13-4	UB63	55	XIO_4[3]
J13-5	UB64	88	XIO_4[4]
J13-6	UB65	89	XIO_4[5]
J13-7	UB66	90	XIO_4[6]

Data Sheet CycloFlex FPGA Development System

J13-8	UB67	127	XIO_4[7]
J13-9	GND	NC	NC
J13-10	GND	NC	NC
Connector-Pin #	Net Name	Cyclone 10 Pin Number	User Code Signal Name
J6-1	UB39	65	XIO_5[0]
J6-2	UB14	66	XIO_5[1]
J6-3	UB15	67	XIO_5[2]
J6-4	UB16	68	XIO_5[3]
J6-5	UB17	71	XIO_5[4]
J6-6	UB18	72	XIO_5[5]
J6-7	UB19	76	XIO_5[6]
J6-8	UB20	77	XIO_5[7]
J6-9	GND	NC	NC
J6-10	GND	NC	NC

Connector-Pin #	Net Name	Cyclone 10 Pin Number	User Code Signal Name
J8-1	UB13	61	XIO_6[0]
J8-2	UB12	60	XIO_6[1]
J8-3	UB11	59	XIO_6[2]
J8-4	UB10	58	XIO_6[3]

Data Sheet CycloFlex FPGA Development System

J8-5	UB8	51	XIO_6[4]
J8-6	UB7	50	XIO_6[5]
J8-7	UB6	49	XIO_6[6]
J8-8	UB40	46	XIO_6[7]
J8-9	+3.3V	NC	NC
J8-10	+3.3V	NC	NC

Connector-Pin #	Net Name	Cyclone 10 Pin Number	User Code Signal Name
J7-1	UB43	28	XIO_7[0]
J7-2	UB42	31	XIO_7[1]
J7-3	UB1	32	XIO_7[2]
J7-4	UB2	33	XIO_7[3]
J7-5	UB41	39	XIO_7[4]
J7-6	UB3	42	XIO_7[5]
J7-7	UB4	43	XIO_7[6]
J7-8	UB5	44	XIO_7[7]
J7-9	GND	NC	NC
J7-10	GND	NC	NC
Connector-Pin #	Net Name	Cyclone 10 Pin Number	User Code Signal Name
J12-1	UB45	7	XIO_8[0]



Data Sheet CycloFlex FPGA Development System

J12-2	UB0	10	XIO_8[1]
J12-3	UB44	11	XIO_8[2]
J12-4	UB38	69	XIO_8[3]
J12-5	UB22	106	XIO_8[4]
J12-6	UB9	23	XIO_8[5]
J12-7	UB58	24	XIO_8[6]
J12-8	UB59	25	XIO_8[7]
J12-9	GND	NC	NC
J12-10	GND	NC	NC

Connector-Pin #	Net Name	Cyclone 10 Pin Number	User Code Signal Name
J14-1	+3.3V	NC	NC
J14-2	GND	NC	NC
J14-3	UB34	111	XIO_3[6]
J14-4	UB33	105	XIO_3[7]
J14-5	NC	NC	NC
J14-6	NC	NC	NC

## 4 LEDs

There are 8 total LEDs on the CycloFlex. All eight are green LEDs.

LED Number	CycloFlex Schematic Signal	LED Signal Name	Cyclone 10 Pin Number
D2	UB0	USER_LEDS[0]	10
D3	UB1	USER_LEDS[1]	32
D4	UB2	USER_LEDS[2]	33
D5	UB3	USER_LEDS[3]	42
D10	UB25	USER_LEDS[4]	114
D15	UB23	USER_LEDS[5]	112
D9	UB24	USER_LEDS[6]	113
D7	UB22	USER_LEDS[7]	106

The CycloFlex also includes one RGB LED. It is a SML-LX0404 LED RGB chip. Each LED with the chip is attached to a current limiting resistor. Each LED leg is controlled by a pin from the Cyclone 10 FPGA.

The LED RGB signals are organized on the following pins from the Cyclone 10 chip:

LED Number	CycloFlex Schematic Signal	RGB Signal Name	Cyclone 10 Pin Number
D11	UB4	LED_RED	43
D11	UB5	LED_BLUE	44

## Data Sheet CycloFlex FPGA Development System

D11	UB6	LED_GREEN	49
-----	-----	-----------	----

Three LED Seven Segment LED Displays are directly controlled from the FPGA. The ACSA02-41SGWA-F01 chip is a current sink connected to Cyclone 10 IO pins. The anode should be connected to +3.3V. The reason for this is the Series resistors are calculated for current limiting based on +3.3V. Each Segment of the Display is mapped

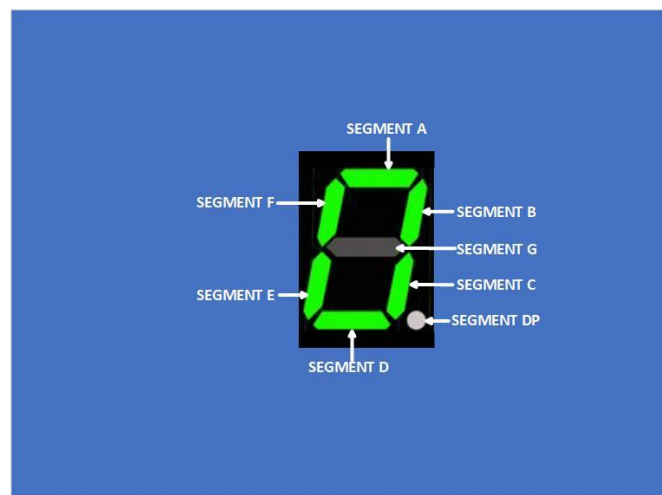

To a pin on the Cyclone 10 FPGA. When the user would like to form a character on the LED Display, the correct segment must be asserted inside the FPGA.

LED Display Number	CycloFlex Schematic Signal	Segment Name	Cyclone 10 Pin Number
1	UB48	Segment A	142
1	UB30	Segment B	141
1	UB56	Segment C	135
1	UB57	Segment D	137

Data Sheet CycloFlex FPGA Development System

1	UB31	Segment E	136
1	UB47	Segment F	143
1	UB46	Segment G	144
1	UB55	Segment DP	133

LED Display Number	CycloFlex Schematic Signal	Segment Name	Cyclone 10 Pin Number
2	UB18	Segment A	72
2	UB17	Segment B	71
2	UB38	Segment C	69
2	UB16	Segment D	68
2	UB15	Segment E	67
2	UB54	Segment F	132
2	UB14	Segment G	66
2	UB39	Segment DP	65

LED Display Number	CycloFlex Schematic Signal	Segment Name	Cyclone 10 Pin Number
3	UB34	Segment A	105
3	UB35	Segment B	100
3	UB51	Segment C	99

## Data Sheet CycloFlex FPGA Development System

3	UB52	Segment D	101
3	UB53	Segment E	103
3	UB33	Segment F	111
3	UB32	Segment G	119
3	UB50	Segment DP	98

## 5 Jumper Selections

Jumper Selections for the CycloFlex allow functions to operate properly on the board.

Component	Function	Net Name	Pin Number on Cylcone 10	Signal in EPT Project
JMP15-1	LED 1 DISPLAY ON/OFF	A_CC	NC	NC
JMP15-2	LED 2 DISPLAY ON/OFF	B_CC	NC	NC
JMP15-3	LED 3 DISPLAY ON/OFF	C_CC	NC	NC
JMP4	RGB ON/OFF		NC	NC

Component	Function	Net Name	Pin Number on Cylcone 10	Signal in EPT Project
JMP5-1	2.7K PULL UP		NC	NC



## Data Sheet CycloFlex FPGA Development System

JMP5-2	CONF_DONE_PULLUP	FT_AD2	NC	NC
JMP5-3	2.7K PULL DOWN		NC	NC

Component	Function	Net Name	Pin Number on Cylcone 10	Signal in EPT Project
JMP6-1	2.7K PULL UP		NC	NC
JMP6-2	NCONFIG_PULLUP	FT_AD3	NC	NC
JMP6-3	2.7K PULL DOWN		NC	NC

Component	Function	Net Name	Pin Number on Cylcone 10	Signal in EPT Project
JMP7-1	CONF_DONE	FT_AD2	NC	NC
JMP7-2	JTAG_TDO	JTAG_TDO	NC	NC
JMP7-3	NC	NC	NC	NC

Component	Function	Net Name	Pin Number on Cylcone 10	Signal in EPT Project
JMP1	1.2V POWER ENABLE		NC	NC



Data Sheet CycloFlex FPGA Development System

## 6 Serial Flash

TBD

Component	Function	Net Name	Pin Number on Cylcone 10	Signal in EPT Project
U10 Pin 1	Chip Select	UB14	66	NC
U10 Pin 2	Data Out	UB15	67	NC
U10 Pin 6	Serial Clock	UB17	71	NC
U10 Pin 5	Data In	UB16	68	NC

## 7 USB to Serial SPI Interface

The USB-C connector provides a path between the Host PC and the CycloFlex Board. It provides a transparent means to power the board and bi-directional communications. The communications occurs over USB. The FTDI driver provides a convient transparent pathway to the CycloFlex Board. The user code in the FPGA is only required to meet the requirements of the FT220X chip.

Component	Function	Net Name	Pin Number on Cylcone 10	Signal in EPT Project
U1	MIOSIO0	UB27	120	SPI_MIOSIO_1
U1	MISO	UB26	115	SPI_MISO
U1	SCLK	UB29	125	SPI_SCLK

## Data Sheet CycloFlex FPGA Development System

U1	SS	UB28	121	SPI_SS
----	----	------	-----	--------

## 8 Pushbutton switches

There are two pushbutton switches on the CycloFlex. Both are momentary contact switches. They include a 1uF cap to ground to debounce both switches. Both of these Push Button Switches are configurable as inputs only to the Cyclone 10. The user code can read the state of the switch or use it as an event to trigger some action in the code.

Component	Net Name	Pin Number on Cyclone 10	Signal in EPT Project Pinout
SW1	PB_SWITCH_1	126	PB_SWITCH__1
SW2	PB_SWITCH_2	91	PB_SWITCH__2

## 9 Input Power

The CycloFlex is designed to be operated from one of two different power sources:

- Standard USB cable from Laptop/PC.
- +4.5 to +5.5 VDC supplied through the DC power jack.  
This provides power for a high-efficiency switching regulator on-board to provide +3.3 VDC. The power supply provides reliable power under dynamic loads and high frequency switching internal to the FPGA.

## 10 FPGA Configuration

The CycloFlex has an internal Flash. This flash is used to configure the FPGA. The has a 5x2 header for





Data Sheet CycloFlex FPGA Development System

use in programming the Cyclone 10 FPGA via JTAG. The connector is located in the bottom right corner of the CycloFlex. It is shrouded and keyed to allow easier insertion.

This connector uses the standard Altera Blaster connector pinout.

Component	Function	Net Name	Pin Number on Cyclone 10	Signal in EPT Project
J2 Pin 1	JTAG_TCK/DCLK	AD0	16	NC
J2 Pin 2	NC	NC	NC	NC
J2 Pin 3	JTAG_TDO/CONF_DONE	JTAG_TDO	20	NC
J2 Pin 4	VCC(TRGT)	+3.3V	NC	NC
J2 Pin 5	JTAG_TMS/nCONFIG	AD3	18	NC
J2 Pin 6	nCK	AD6	21	NC
J2 Pin 7	DATAOUT	AD5	13	NC
J2 Pin 8	nCS	AD7	8	NC
J2 Pin 9	JTAG_TDI/ASDI	AD1	15	NC
J2 Pin 10	GND	GND	NC	NC

## 11 CycloFlex Power

### 11.1.1 Core Board Power Budget

Device	Part Number	+1.2V Power	+2.5V Power	+3.3V Power
FPGA	10CL016E144C8	??? Defined by user code. EPT-Transfer-Demo code: 50mA	10mA	??? Defined by user code. . EPT-Transfer-Demo code: 50mA
USB SPI Controller	FT220X			5mA
Serial Flash	S25FL127S			50mA
50MHz Oscillator	FXO-HC536R-66			47 mA
RGB LED	SML-LX0404SIUPGUSB			18 mA
Seven Segment LED Display	ACSA02-41SGWA-F01			100 mA (all three displays active)
User LEDs	APT1608CGCK			20 mA
<b>Total</b>		<b>50mA</b>	<b>10mA</b>	<b>290mA</b>

\*Theoretical Values only. This data needs to be validated